

MAZAK

V-Type (Axial) Drilling & Milling Heads

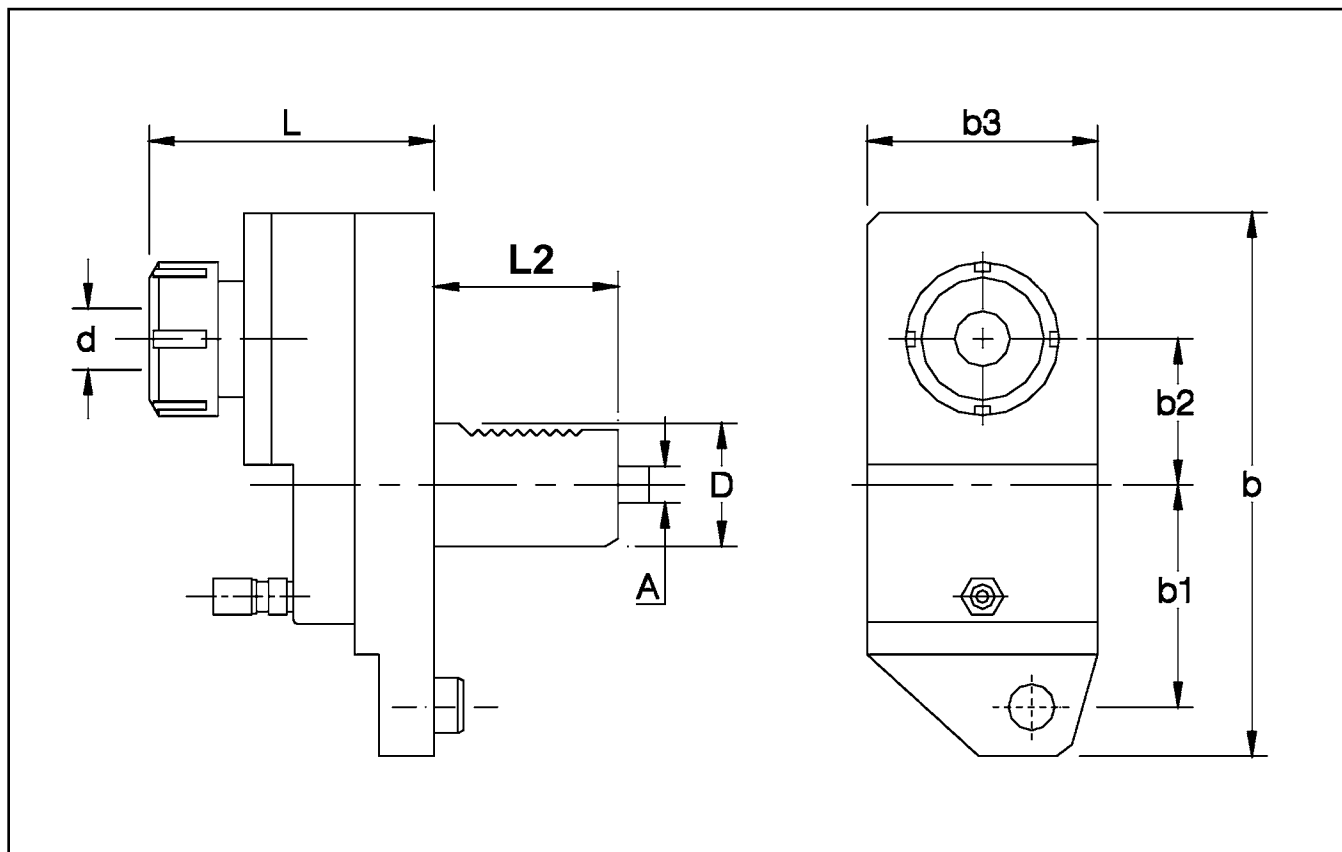

ORDER NO.	D (mm)	Machine	d	A (mm)	L2 (mm)	L (mm)	b (mm)	b1 (mm)	b2 (mm)	b3 (mm)	RPM Max	Ratio	Nm	Kg.
TE40F2045	40	SQ 10 M/C	ECX/ER32	10	60	94	174	70	50	74	6000	1:1	50	5.0
TE40F2046	40	SQ 15 MY	ECX/ER32	10	70	94	174	70	50	74	6000	1:1	50	6.0
TE40F2046	40	SQT 250 MS	ECX/ER32	10	70	94	174	70	50	74	6000	1:1	50	6.0

MAZAK H-Type (Radial) Drilling & Milling Heads

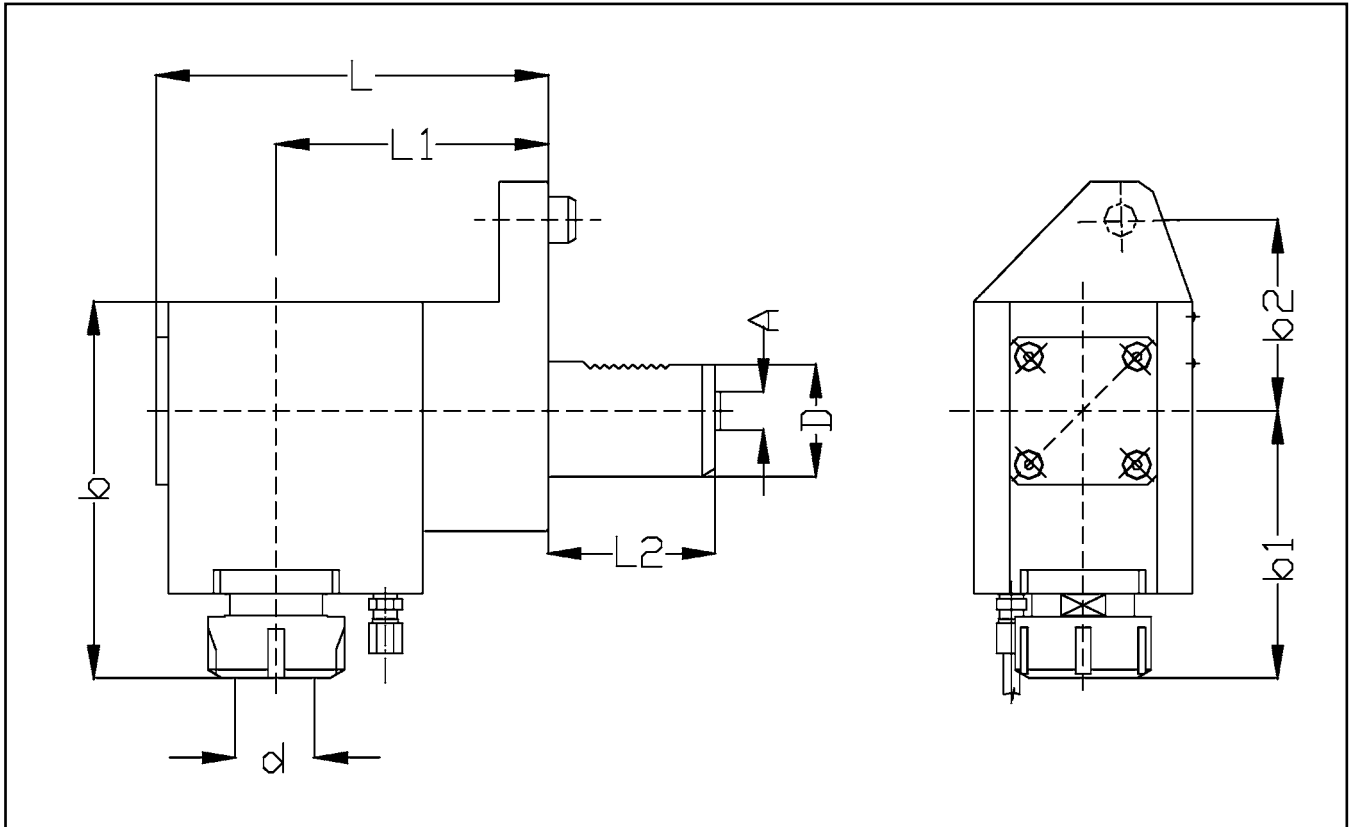

ORDER NO.	D (mm)	Machine	d	A (mm)	L2 (mm)	L (mm)	L1 (mm)	b (mm)	b1 (mm)	b2 (mm)	b3 (mm)	RPM Max	Ratio	Nm	Kg.
TE40B2045	40	SQ 10 M/C	ECX/ER32	10	60	144	100	138	98	70	74	6000	1:1	50	8.0
TE40B2046	40	SQ 15 MY	ECX/ER32	10	70	174	130	138	98	70	74	6000	1:1	50	9.0
TE40B2046	40	SQT 250 MS	ECX/ER32	10	70	174	130	138	98	70	74	6000	1:1	50	9.0

MAZAK

H-Type (Radial) Drilling & Milling Heads (Subspindle)

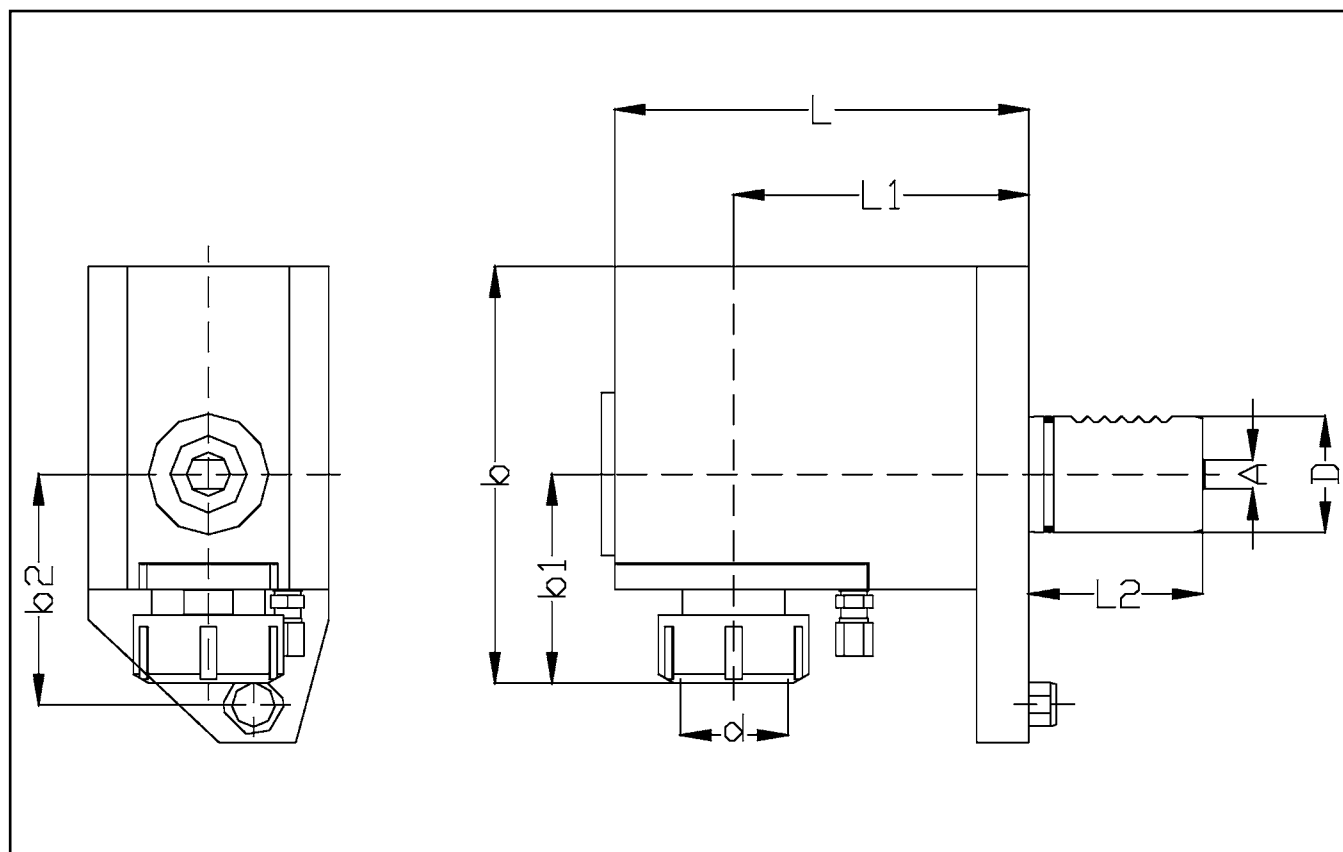

ORDER NO.	D (mm)	Machine	d	A (mm)	L2 (mm)	L (mm)	L1 (mm)	b (mm)	b1 (mm)	b2 (mm)	RPM Max	Ratio	Nm	Kg.
TE40C2045S	40	SQ 10 M/C	ECX/ER32	10	60	144	100	138	40	70	6000	1:1	50	9
TE40C2046S	40	SQ 15 MY	ECX/ER32	10	70	174	130	138	40	70	6000	1:1	50	10
TE40C2046S	40	SQT 250 MS	ECX/ER32	10	70	174	130	138	40	70	6000	1:1	50	10

MAZAK

H-Type (Radial) Double Drilling Milling Heads

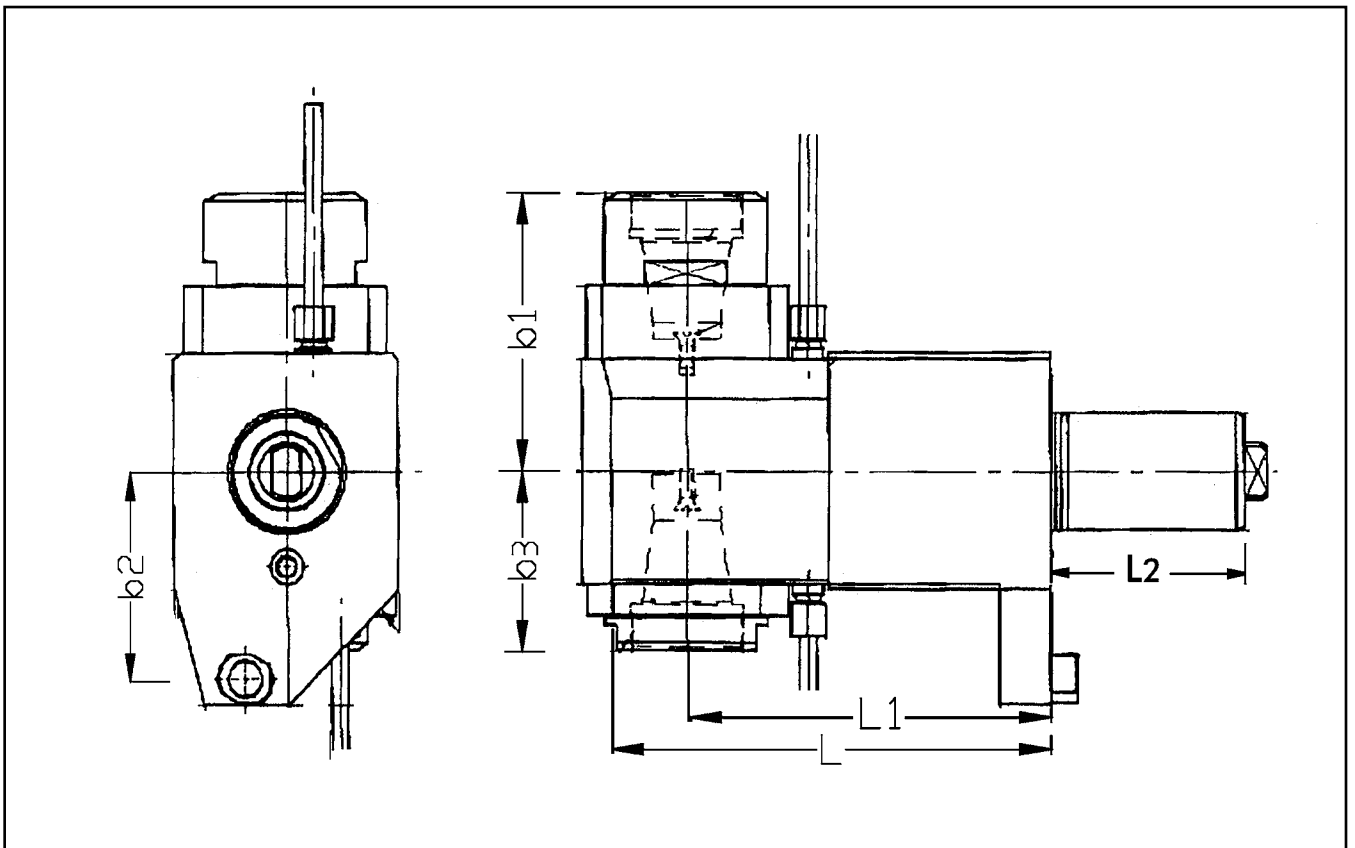

ORDER NO.	D (mm)	Machine	d	A (mm)	L2 (mm)	L (mm)	L1 (mm)	b1 (mm)	b2 (mm)	b3 (mm)	RPM Max	Ratio	Nm	Kg.
TE40L2046	40	SQ 15 MY	ECX/ER32	10	70	137	100	94.5	70	60.5	6000	1:1	50	12
TE40L2046	40	SQT 250 MS	ECX/ER32	10	70	137	100	94.5	70	60.5	6000	1:1	50	12

MAZAK Universal Angle Drilling-Milling Heads

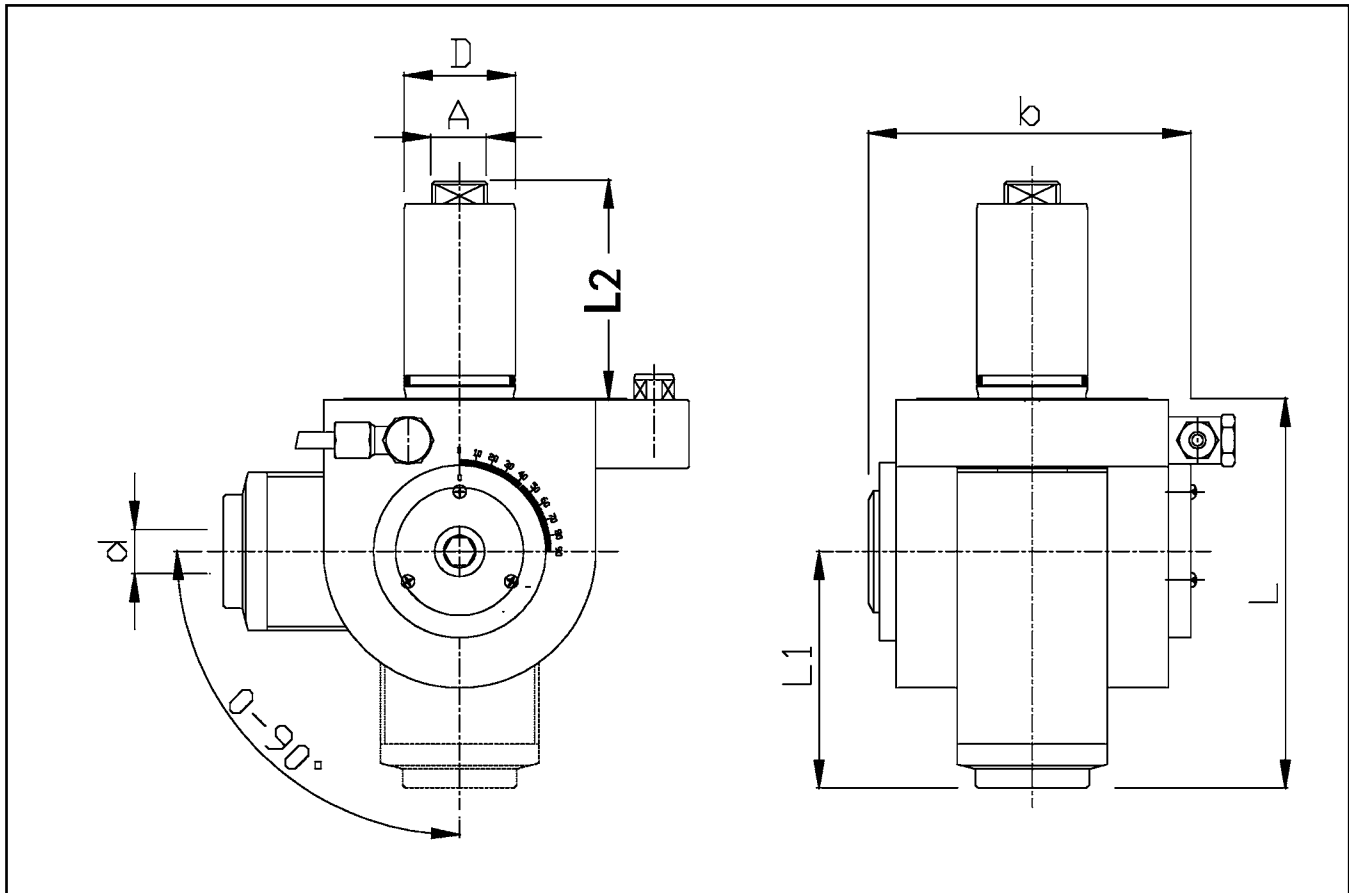

ORDER NO.	D (mm)	Machine	d	A (mm)	L2 (mm)	L (mm)	L1 (mm)	b (mm)	RPM Max	Ratio	Nm	Kg.
HE40E1645	40	SQ 10 M/C	ECX/ER25	10	60	140	85	116	6000	1:1	25	6.9
HE40E1646	40	SQ 15 MY	ECX/ER25	10	70	140	85	116	6000	1:1	25	6.9
HE40E1646	40	SQT 250 MS	ECX/ER25	10	70	140	85	116	6000	1:1	25	6.9

MAZAK

V-Type (Axial) Drilling & Milling Heads

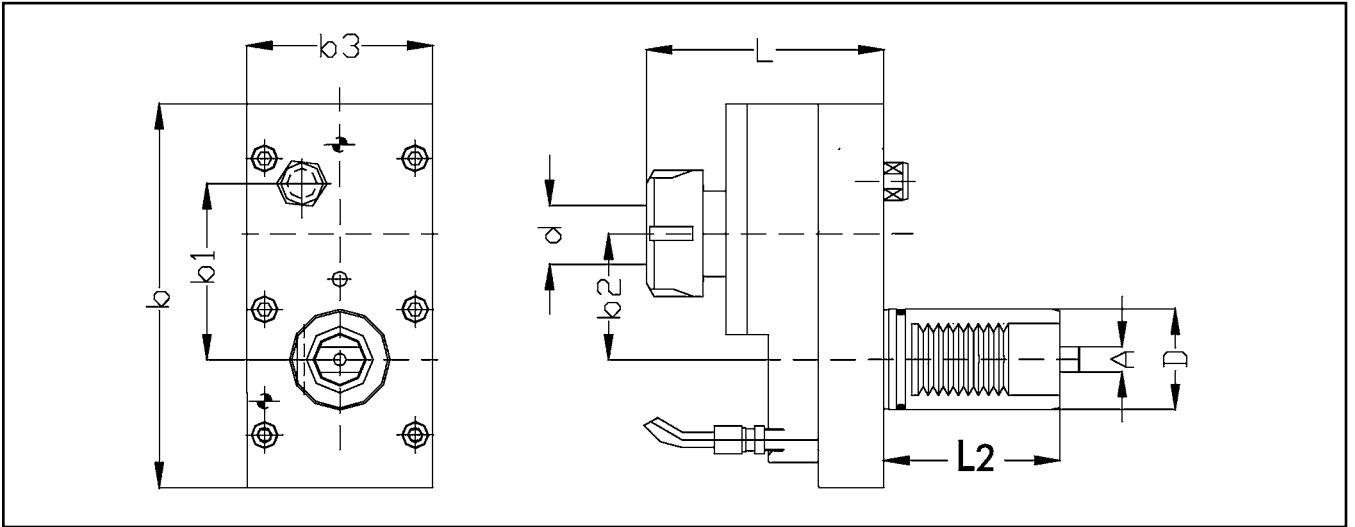

ORDER NO.	D (mm)	Machine	d	A (mm)	L2 (mm)	L (mm)	b (mm)	b1 (mm)	b2 (mm)	b3 (mm)	RPM Max	Ratio	Nm	Kg.
TE40F2047	40	MULTIPLEX 6200	ECX/ER32	10	70	95	153	98	50	74	6000	1:1	50	6

H-Type (Radial) Drilling & Milling Heads

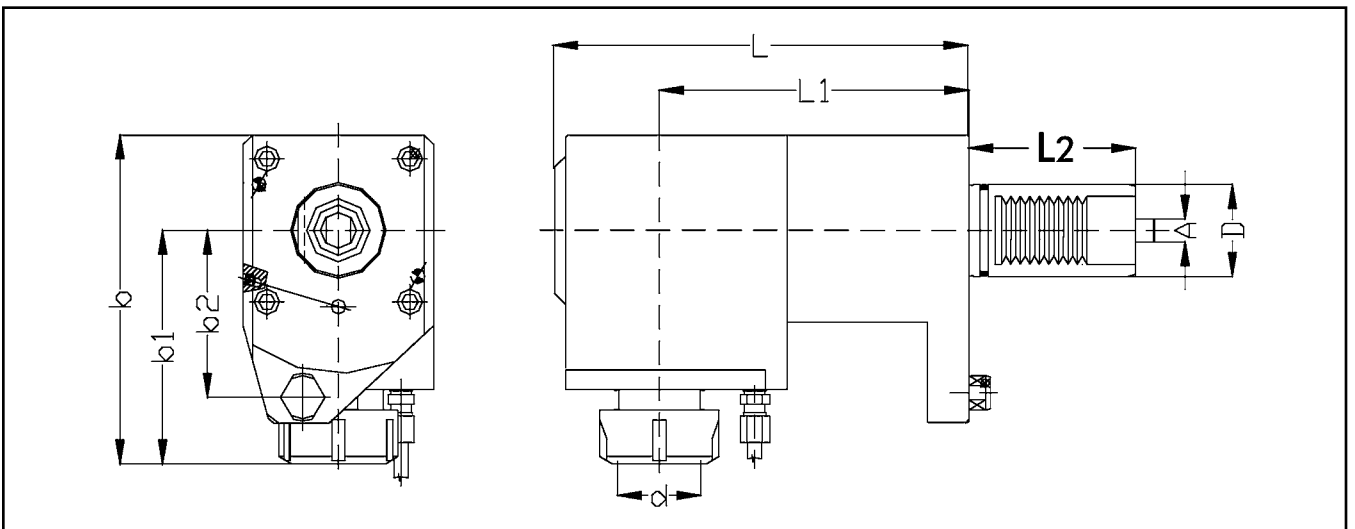

ORDER NO.	D (mm)	Machine	d	A (mm)	L2 (mm)	L (mm)	L1 (mm)	b (mm)	b1 (mm)	b2 (mm)	RPM Max	Ratio	Nm	Kg.
TE40B2047	40	MULTIPLEX 6200	ECX/ER32	10	70	174	130	138	98	70	6000	1:1	50	9

MAZAK Universal Angle Drilling-Milling Heads

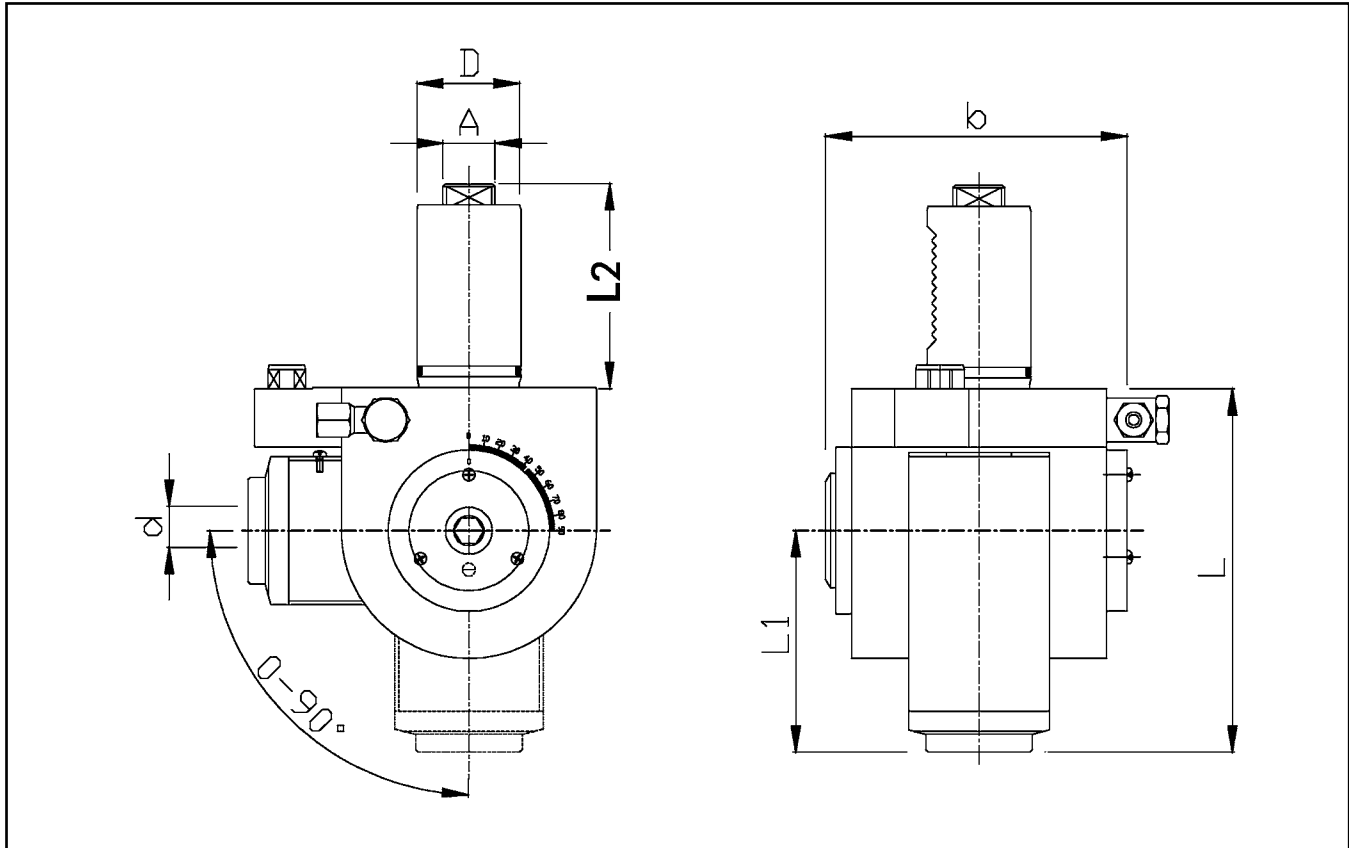

ORDER NO.	D (mm)	Machine	d	A (mm)	L2 (mm)	L (mm)	L1 (mm)	b (mm)	RPM Max	Ratio	Nm	Kg.
HE40E1647	40	MULTIPLEX 6200	ECX/ER25	10	70	140	85	116	6000	1:1	25	6.9